

FS3002 Grease Flow Sensor

RELIABLE

FAST

COMPACT

Adjustable Flow Sensor (Flow Monitor) for Grease

■	Base mounted for quick change with minimal downtime
■	Micro connector for quick electrical connections
■	Easy adjustment with LED flow indicator
■	Tamper resistant adjustment cover

■	Functions with almost any grease or heavy oil
■	Short response time for high production greasing
■	Dependable inductive proximity circuit with digital output
■	Operates with 10 to 30 Volts DC

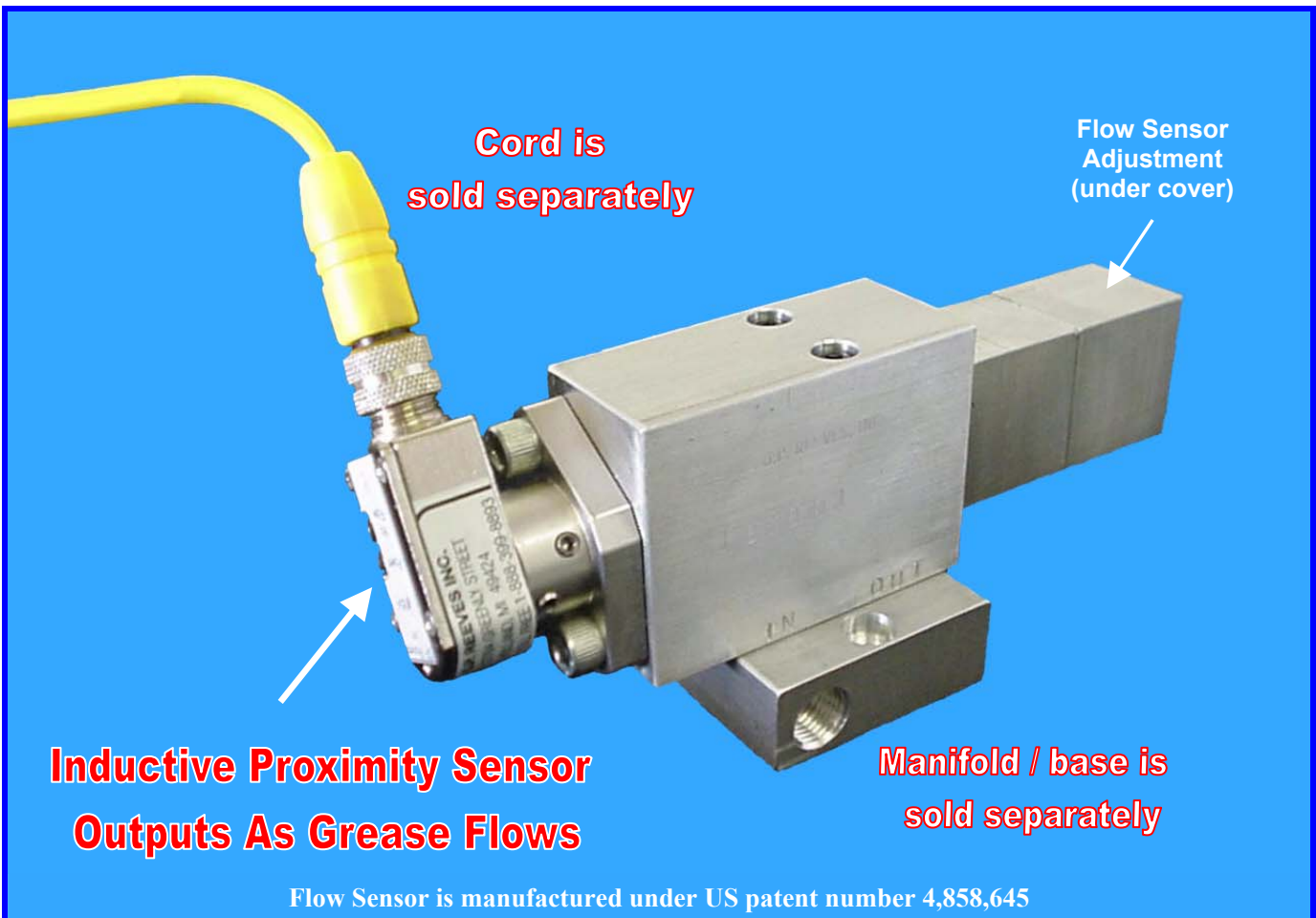

G. P. Reeves Inc. 12764 Greenly Street Holland, MI 49424
 Phone: 888.399.8893 Fax: 616.399.8867 Web Site: <http://gpreeves.com>

RELIABLE AND FAST

The FS3002 Flow Sensor uses a sealed electronic inductive proximity circuit, non-magnetic steel ball, and a precision-machined nylon seat for high speed, accurate, reliable operation.

COMPACT & BASE MOUNTABLE

The FS3002 Flow Sensor is small, (about 7" long, 2" high, and 1 1/4" wide) and can be installed on a base that is only 3/4" high. Multiple sensors can be installed on multi-station bases on 1 3/4" centers. The male plug-in Micro connector CAN rotate through 304 deg. for wiring flexibility.

FS3002 SPECIFICATIONS

Media	NLGI #0 through NLGI #3 grease compatible with neoprene seals	Response Time with increasing flow **	0.10 second when adjusted to sense increasing flow. 0.20 second when adjusted to sense decreasing flow
Flow Range **	0.10 to 20 cc per second (Inlet to Outlet) <u>DO NOT REVERSE FLOW</u>	Response time with decreasing flow **	0.10 second when adjusted to sense decreasing flow. 0.20 second when adjusted to sense increasing flow
Pressure Rating	3000 p.s.i. (206 bar)	Adjustment Mechanism	Includes locking nut and cover
Material Inlet Port	1/4" diameter with flat gasket to fit base	Supply Voltage	10-30 VDC
Material Outlet Port	3/16" diameter with flat gasket to fit base	Switch Output	<u>On</u> when flow rate is below the set point
Ambient Temperature	32 to 140° F. (0 to 60° C.)	Switch Load Capacity	200 mA
Dimensions	See Drawing KA4558	Switching	PNP
Manifold or Base	Any G. P. Reeves FSM2000 series	Shipping Weight	2 lb. less base and cord

** With NLGI #00 through #2 Grease at 70° F. (Grease viscosity, plumbing, and distance will affect response time.)

OPTIONS AND ACCESSORIES

Part Number	Description	Part Number	Description
FSM2001	Single station base with 1/8 NPT side ports	FSM2000-5	Five station base with 1/8 NPT end ports
FSM2002	Single station base with 1/4 NPT side ports	FSM2000-6	Six station base with 1/8 NPT end ports
FSM2003	Single station base with 3/8 NPT side ports	FSM2000-7	Seven station base with 1/8 NPT end ports
FSM2000-1	Single station base with 1/8 NPT end ports	FSM2000-8	Eight station base with 1/8 NPT end ports
FSM2000-2	Two station base with 1/8 NPT end ports	1850	5 meter long straight with Micro Connector
FSM2000-3	Three station base with 1/8 NPT end ports	1851	5 meter long 90 deg. cord with Micro Connector
FSM2000-4	Four station base with 1/8 NPT end ports		

G. P. Reeves Inc. 12764 Greenly Street Holland, MI 49424

Phone: 888.399.8893

Fax: 616.399.8867

Web Site: <http://gpreeves.com>

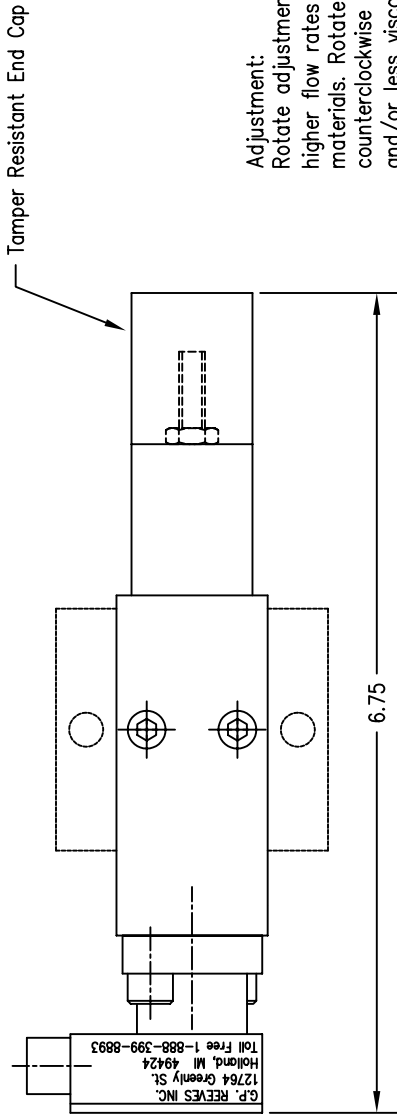

Adjustment:
 Rotate adjustment screw clockwise for higher flow rates and/or more viscous materials. Rotate adjustment screw counterclockwise for lower flow rates and/or less viscous materials.

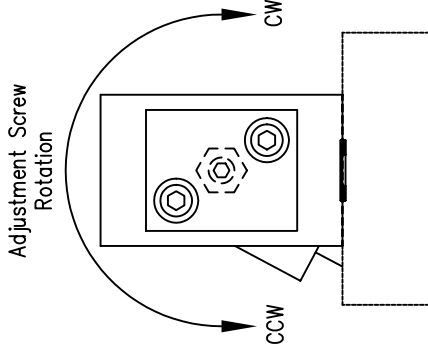
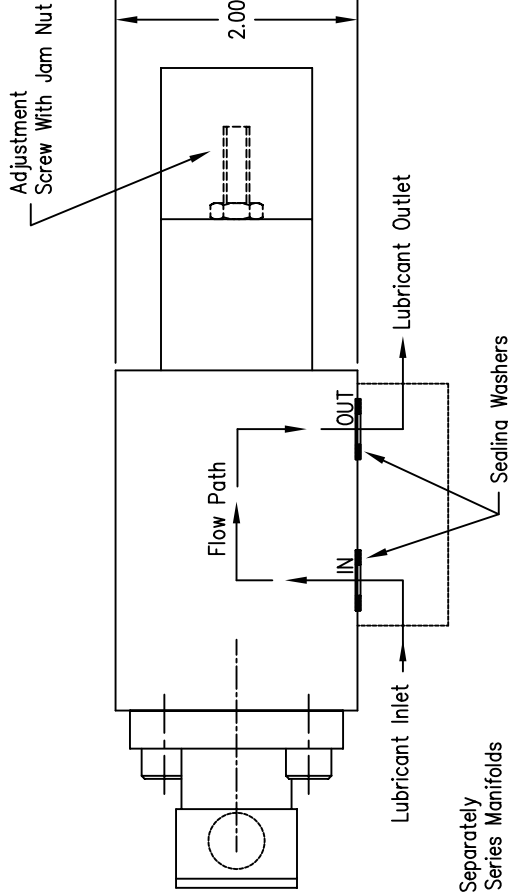
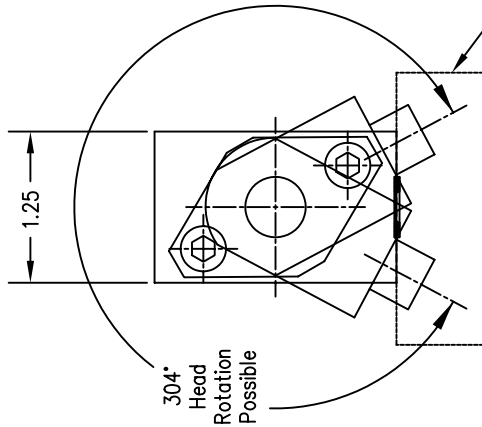

Do Not Reverse Flow

WIRING DIAGRAM FOR PNP PROXIMITY SENSOR

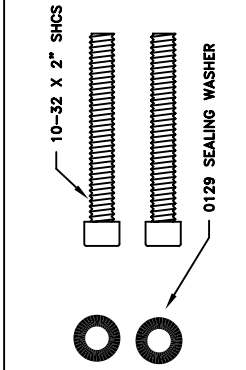
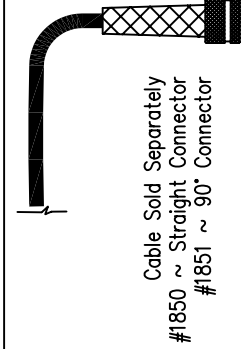
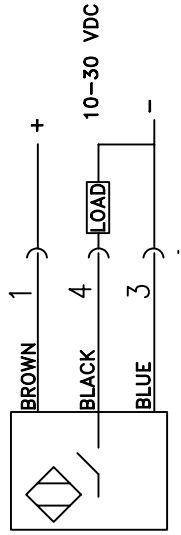

KEY	DESCRIPTION	REQ
LUBE LOGIC	G.P. REEVES INC. 12764 GREENLY STREET HOLLAND, MI 49424, USA	
SCALE	.XXX = ± .005 .XX = ± .015 .X = ± 1/32	
DATE	10/25/01	
DRAWN BY: KAH		
REVISED		
FS3002 Flow Sensor		
Sales Drawing		Sheet 1 of 3
		DRAWING NUMBER KA4558