

# GUS1000

## Grease Uninterruptible Source

**SELF-CONTAINED GREASE SUPPLY BACKUP REMOVES AIR**

- **Allows Continued Production During Grease Tote, Canister, Drum, and Pail changes**
- **Finds and removes voids and air from grease**

- Alerts user of grease supply problems while operating
- Controlled by integral microprocessor
- Sends only airless grease to downstream dispensing components
- Will function with heavy NLGI #2 lubricating grease

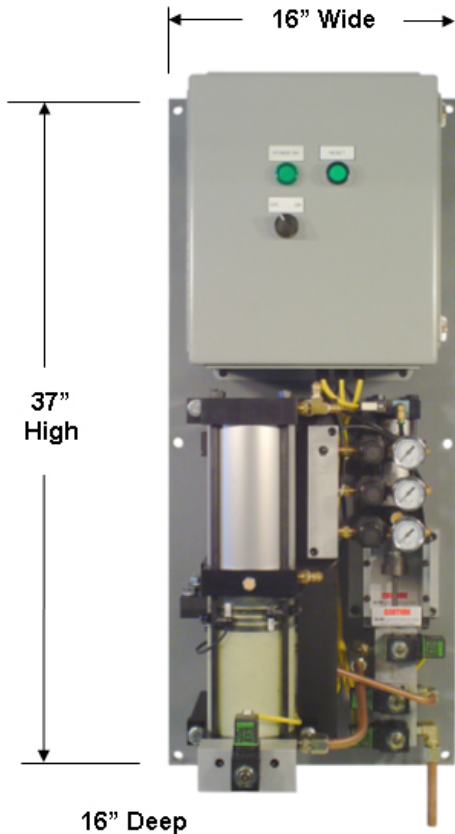

### WHO NEED GUS?

Are you applying grease to production parts?  
(non-maintenance greasing)

Are you are tired of having reject parts caused by air bubbles in your grease?

If you have a system that detects air and shuts down for correction, is shutting down inconvenient?

Do you want only airless grease to be applied or injected into your production parts?

Are you are disgusted with having your production line shut down during drum or pail changes at your central grease pump?

Are you "fed up" with shutdowns caused by air in the grease shortly after pail or drum changes?

### DESCRIPTION

GUS1000 Grease Uninterruptible Source removes air from grease and facilitates continued operation during grease supply (tote, canister, drum or pail) interruptions. GUS1000 has 1049 cc inlet grease reservoir and a 49 cc outlet grease accumulator. GUS1000 is controlled by an integral microprocessor and requires 120 v.a.c. 50/60 Hz and compressed air for operation. Grease inlet and outlet port size is SAE 8 (1/2"). Maximum grease inlet pressure is 3000 p.s.i. Grease outlet pressure is adjustable between 400 and 1,500 p.s.i.

### BACKUP TIME

The GUS1000 has a backup-time of 95 minutes at its maximum recommended grease usage of 12 cc per minute.

### GUS Notes

GUS1000 is designed to supply grease to multiple independent randomly operated grease dispensers.

If you need large amounts of grease to be dispensed from only one or two nozzles, check out our AAGP dispensers.

GUS is manufactured exclusively by G. P. Reeves Inc. under US patent number 6,053,285.

GUS is self-controlled, and will communicate with your PLC. See CAT-GUS DESCRIPTION for sequence of operation.

See CAT-PRESSURE FLOW CONFIRMATION to see how we prove grease flow at your dispense nozzle.

### Install GUS between pump and dispensers

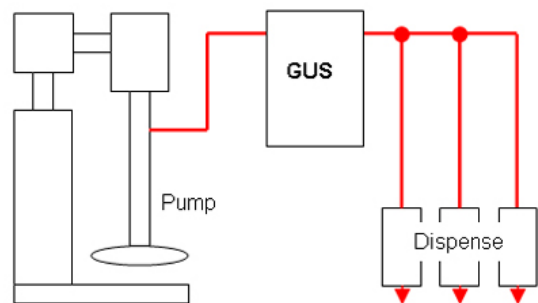

**G. P. Reeves Inc. 12764 Greenly Street Holland, MI 49424**

**Phone: 888.399.8893**

**Fax: 616.399.8867**

**Web Site: <http://gpreeves.com>**